

CAN Switch Board (CSB)

The Cosworth CSB is a fully customised CAN Switch Board designed to be light and compact enough to fit onto a steering wheel. The CSB allows complicated steering wheel and connector looms to be reduced in wire count and complexity whilst also providing weight and cost reductions. The CSB has been developed with this in mind allowing for simple integration onto the back of any steering wheel requiring a minimum of only 4 wires.

The CSB supports up to 12 digital switch inputs, 5 analogue inputs, 5 LED outputs and also features 2 Opto-Isolated switch input/outputs. The CSB is fitted with a 16 position hex switch allowing simple

switching between the 8 preset CAN identification ranges. CAN termination is provided via a solder link. The default CAN identification addresses are stored in non-volatile memory and can be changed by using the CSB configuration menu which is available via the RS232 interface.

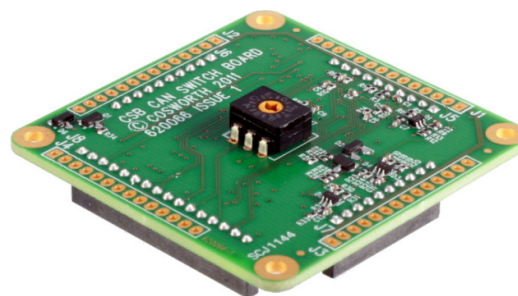

Specifications

Electrical Data	
Supply Voltage	6.5Vdc to 18Vdc
Supply Protection	Reverse and over voltage
Supply Current	56mA@12V
Temperature Operational	-30°C to +60°C
Temperature Storage	-20°C to +70°C

I/O Information	
1x CAN	1Mbit, 512k, 256k, 128k software selectable, with 120Ω selectable termination
5x Analogue Inputs	0-5V range @ 100Hz, with a 1MΩ pull-down resistor.
12x Digital Switch Inputs	0-5V range @ 100Hz, with a 10kΩ pull-up resistor.
5x LED Outputs	5V Anode supply with a 330Ω series resistor.
1x Protected 5V Excitation	200mA @ 25°C 110mA @ 70°C
1x Protected 12V Excitation	Reverse protected

I/O Information	
2x Opto-Isolated Outputs	0-VBatt output, with a maximum 100mA load and 0.8Ω resistance.
Communication Ports	
1x Serial Port (Debug use only)	RS232

Mechanical Data	
Size without connectors	50 x 50 x 12.45 mm
Weight	11 grams

Ordering Information

Part Number	
13I-620079	CSB Stand Alone
10I-620083-1	CSB 3 and 6 Hole steering wheel mounting plate

Installation

When installing the CAN Switch Board:

- Select a position where the CSB will not be in constant contact with water, fuel or oil.
- Wires should be soldered from back to front so that silicone can be used for strain relief against the internal connectors.
- Protect the CSB from vibration. Non corrosive silicone should be used once wires have been fitted.
- Try not to place the CSB near sources of electrical interference i.e. ignition coils, plug leads, ECUs, alternators and telemetry antennas.
- Optional CSB Steering wheel mounts should be used when fitting to a steering wheel.
- As standard the PCM mounting points are isolated from the PCB Ground if required the PCB Ground can be connected to the mounting holes using the solder links***

Dimensions

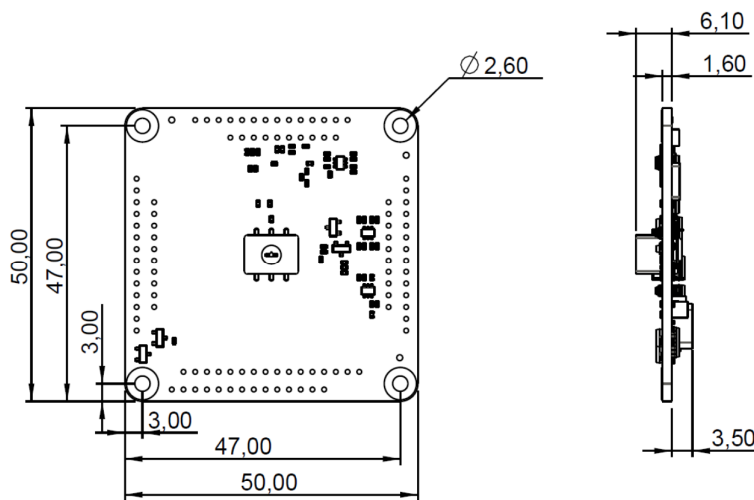

CSB Steering Wheel Housing

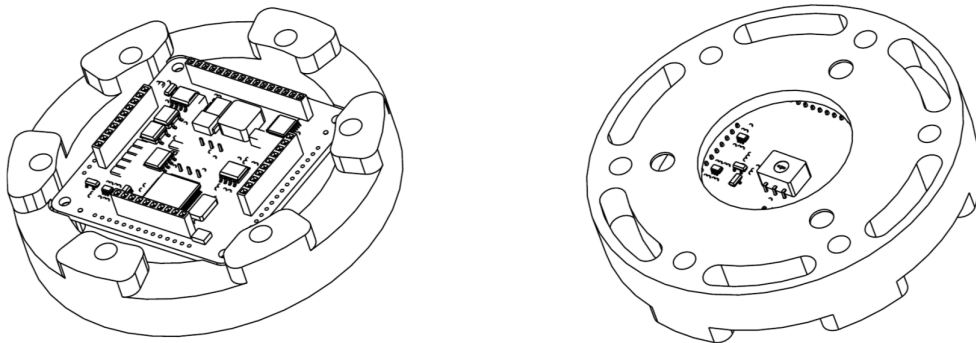

The CSB housing has been designed to allow the CSB to be fitted onto the back of any steering wheel. The spacer has fittings for either a 3 or 6 hole boss.

Connector Information

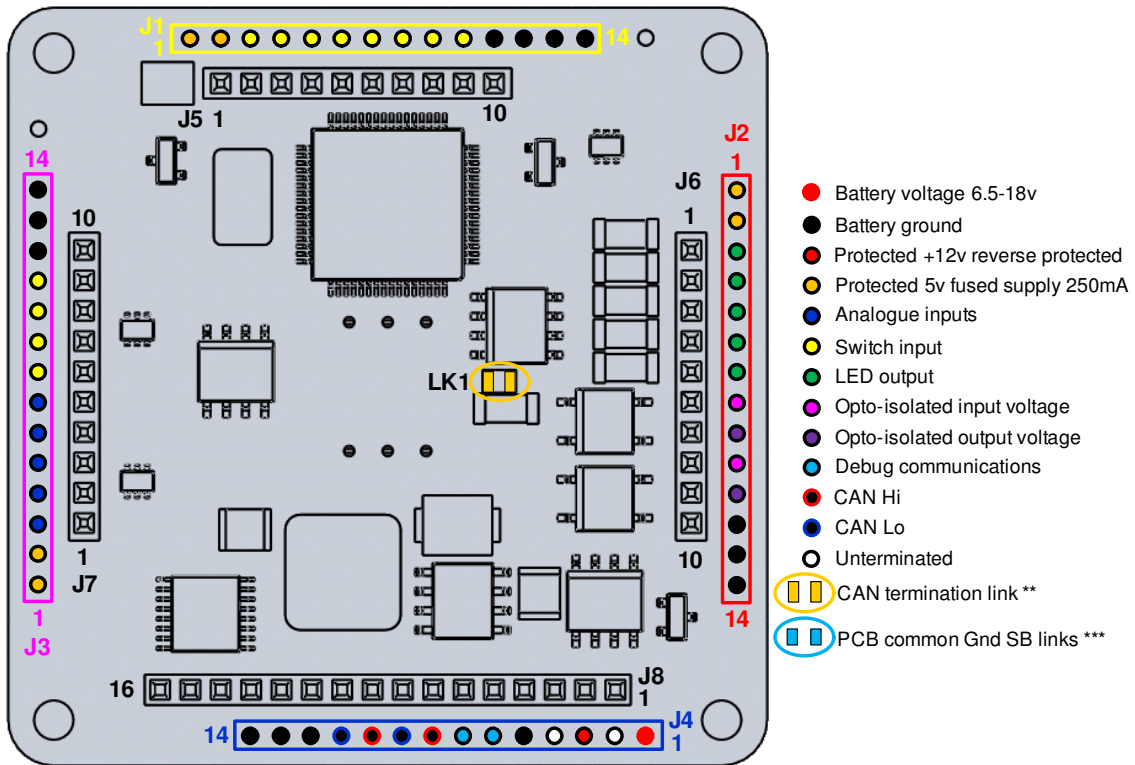

- Battery voltage 6.5-18v
- Battery ground
- Protected +12v reverse protected
- Protected 5v fused supply 250mA
- Analogue inputs
- Switch input
- LED output
- Opto-isolated input voltage
- Opto-isolated output voltage
- Debug communications
- CAN Hi
- CAN Lo
- Unterminated
- ▭ CAN termination link **
- ▭ PCB common Gnd SB links ***

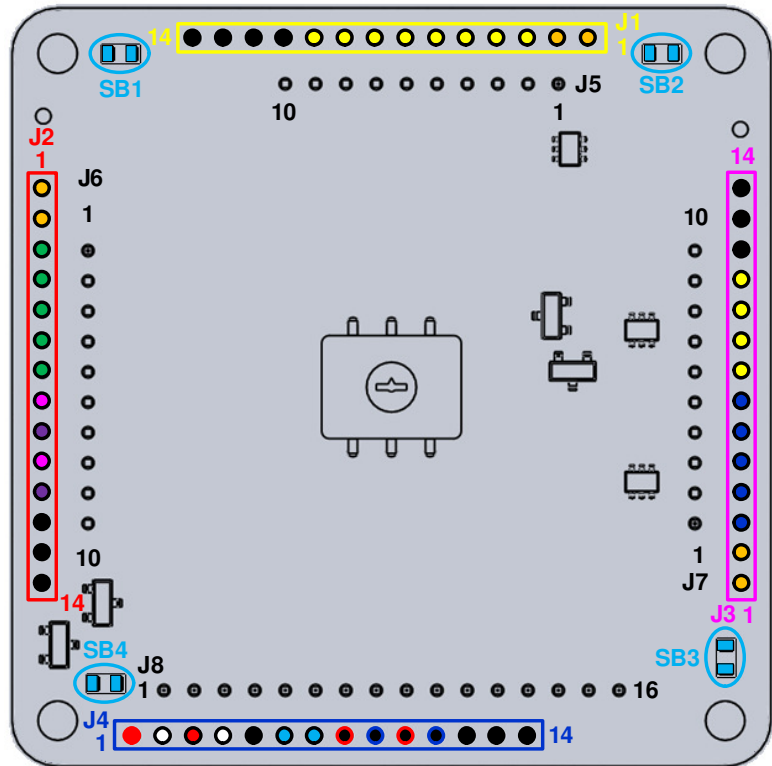

** CAN Termination is enabled by shorting LK1
 *** PCB Common Ground made using SB1-4

J1 ADI and Switch Input

Pin	Name	Function
1	+5VPROT	Protected +5V
2	+5VPROT	Protected +5V
3	SW8	Switch input 8
4	SW9	Switch input 9
5	SW10	Switch input 10
6	SW1	Switch input 1
7	SW2	Switch input 2
8	SW3	Switch input 3
9	SW11	Switch input 11
10	SW12	Switch input 12
11	GND	0V
12	GND	0V
13	GND	0V
14	GND	0V

J3 AI and ADI Input

Pin	Name	Function
1	+5VPROT	Protected +5V
2	+5VPROT	Protected +5V
3	AI1	Analogue input 1
4	AI2	Analogue input 2
5	AI3	Analogue input 3
6	AI4	Analogue input 4
7	AI5	Analogue input 5
8	SW4	Switch input 4
9	SW5	Switch input 5
10	SW6	Switch input 6
11	SW7	Switch input 7
12	GND	0V
13	GND	0V
14	GND	0V

J2 LED and Opto-isolator Outputs

Pin	Name	Function
1	+5VPROT	Protected +5V
2	+5VPROT	Protected +5V
3	LED1	LED 1 output driver
4	LED2	LED 2 output driver
5	LED3	LED 3 output driver
6	LED4	LED 4 output driver
7	LED5	LED 5 output driver
8	OUT-I1	Opto-isolator 1 input voltage
9	OUT-O1	Opto-isolator 1 output voltage
10	OUT-I2	Opto-isolator 2 input voltage
11	OUT-O2	Opto-isolator 2 output voltage
12	GND	0V
13	GND	0V
14	GND	0V

J4 System Connector

Pin	Name	Function
1	Batt +	Battery +12V input
2	N/C	Must be left un-terminated
3	PBATT+	Protected battery +12V
4	N/C	Must be left un-terminated
5	GND	0V
6	DEBRX	RS232 serial data PC to PIC
7	DEBTX	RS232 serial data PIC to PC
8	CANH	CAN Hi (Linked with pin 10)
9	CANL	CAN Lo (Linked with pin 11)
10	CANH	CAN Hi (Linked with pin 8)
11	CANL	CAN Lo (Linked with pin 9)
12	GND	0V
13	GND	0V
14	GND	0V

Recycling and Environmental Protection

Cosworth Electronics is committed to conducting its business in an environmentally responsible manner and to strive for high environmental standards.

Manufacture

Cosworth products comply with the appropriate requirements of the Restriction of Hazardous Substances (RoHS) directive (where applicable).

Disposal

Electronic equipment should be disposed of in accordance with regulations in force and in particular in accordance with the Waste in Electrical and Electronic Equipment directive. (WEEE).

Battery

This equipment does not contain a battery.

