

BADENIA 5

Quick links

[Overview](#)

[Product Variant Matrix](#)

[Dimensions](#)

[Installation](#)

[Connector Information](#)

[Recycling and Environmental Protection](#)

COSWORTH

Enabling Greatness for over  years

©Copyright Cosworth Electronics Ltd | All Content is Proprietary and Confidential. Brookfield
Technology Centre, Twenty Pence Road, Cottenham, Cambridge, CB24 8PS

BADENIA 5

Overview

- 40 x analogue inputs
- 8 x independent CAN ports
- Fast 1GB Ethernet connectivity
- MATLAB/Simulink® strategy control

The Badenia 5 from Cosworth offers high-rate data logging, control, outputs and huge processing capabilities. Featuring up to 40 x analogue inputs, 4 x CAN ports, LIN, and 5 x digital inputs, the Badenia 5 is an extremely capable data logger.



Its 4 x HSD/PWM outputs result in the Badenia 5 being the ideal unit for complete vehicle control. Cosworth's auto-coding platform features as part of the Badenia 5 offering. This allows for custom strategies/models to be developed in a MATLAB/ Simulink® environment and deployed on the Badenia 5.

Electrical data	
Operating Voltage	6.6 to 31.5V
Current consumption**	572mA @ 14V
Communication	
Ethernet	1x 1000MB/s 2x 100MB/s
CAN Ports	4 x Independent CAN Ports Max BAUD rate; 1MBit/s 64 x Message Buffers per Port Software selectable 120Ω Resistor
LIN Ports	2x LIN Bus Master
EtherCAT	1 x EtherCAT Master
Serial Ports	2 x Bi-Directional RS232 Ports Split Tx and Rx Rates Max BAUD Rate: 115200
Debug	1 x Bi-Directional RS232 Fixed@115200 BAUD Rate
Mechanical data	
Size	118 x 120 x 34 mm
Weight	472 grams
Environmental	IP66
Vibration	Cosworth DV-V®
Case Material	6082-T6 Anodized
Operating Internal Temp	-20°C to + 70°C
Storage Temp	-20°C to + 80°C

I/O	
Logging Specifications	See 'Token Logging Options' below.
Analogue Inputs	40 x 0-5 Inputs 16-bit resolution Filtered 3dB freq of ~15.9kHz 2.1M Ω Impedance AIN 1-8 selectable 1K8 Pull Up
Digital Inputs	4 x High Frequency (10kHz) supports hall effect /VRS/DF11i 2 x Support IR Lap Timing & Switches Selectable 3k3 pull-up to 5V or Level Shift for Passive Sensors
Excitations	6 x 5V ±0.25% Supply @ 100mA 4 x Software Selectable 5V/12V 12V ±0.5% Supply @ 700mA
HSD / PWM	4 x HSD / PWM Battery voltage @ 700mA(max) 400Hz Maximum PWM Frequency
Motion Sensor	Accelerometer 3 axis ±16G
Internal Monitoring	Battery Voltage Box Temperature Excitation Voltage
LEDs	7 x System Status LEDs



Product Variant Matrix

Token Logging Options

Variant	520	540	560
Token Part Number	01P-650080-520	01P-650080-540	01P-650080-560
Logging Capacity (MB)	4,096	8,192	12,880
Cont. Sampling Rate (Hz)	1,000	1,000	1,000
Cont. Bandwidth (bytes/sec)	400,000	1,200,000	1,600,000
High Speed Sampling Rates (Hz)	10,000	20,000	20,000
Total no. of Channels	16,384	16,384	16,384
Maths Channels	500	750	1000
Logic Channels	Enabled	Enabled	Enabled
Analogue Inputs	20	30	40
Digital Inputs	7 (6x Df11i)	8 (7x Df11i)	10 (8x Df11i)
CAN Ports	6	6	8
LIN Ports	2	2	2
EtherCAT Ports	1	1	1
Ethernet Displays	48	48	48
Auto Coding Customer	Enabled	Enabled	Enabled
Auto Coding Developer	Upgrade option	Upgrade option	Upgrade option
Telemetry Tables	3	3	3





Ordering information

Badenia 5 Series	01L-650080
520 Token	01P-650080-520
540 Token	01P-650080-540
560 Token	01P-650080-560
Auto Coding Developer Token	01P-650080-AC-DEV

Compatible devices

CDU 4.3	01L-650100
CDU 7.0	01L-650080
CDU 10.3	01D-640060
Centaurus 5 Mk2	01L-610140
SJU	01L-650050
CCW Mk3	01D-641350

Software information

	Pi Toolset	Configuration software for power control and logging (v9 and above)
	Pi Toolbox	Professional Data Analysis (v10 and above)
	API	Cosworth DAE Engine for Real time Data pipelines.
	Auto-Coding via MATLAB/Simulink®	Customer auto-coding via MATLAB/ Simulink® and Cosworth Workspace Editor coming soon.

LED Indicator Definitions



Legend	Function	Sequence	Period										
	No power to the Unit	Off											
	Initialising and waiting for clock sync	On	█	█	█	█	█	█	█	█	█	█	█
	Unit operational	50% Flash (1Hz)	█	█	█	█	█	█	█	█	█	█	█
	During startup a single flash LED test	Long Single Pulse	█	█	█	█	█	█	█	█	█	█	█
	Normal running operation	Off											
	Logger error or no dataset loaded	On	█	█	█	█	█	█	█	█	█	█	█
	During startup a single flash LED test	Long Single Pulse	█	█	█	█	█	█	█	█	█	█	█
	Normal running operation	Off											
	Logger full and overwriting data	On	█	█	█	█	█	█	█	█	█	█	█
	1000Base T. No connection established	Off											
	Connection established	50% Flash (1Hz)	█	█	█	█	█	█	█	█	█	█	█
	Communication active	Flickering	█	█	█	█	█	█	█	█	█	█	█
	100Base T. No connection established	Off											
	Connection established	50% Flash (1Hz)	█	█	█	█	█	█	█	█	█	█	█
	Communication active	Flickering	█	█	█	█	█	█	█	█	█	█	█
	100Base T. No connection established	Off											
	Connection established	50% Flash (1Hz)	█	█	█	█	█	█	█	█	█	█	█
	Communication active	Flickering	█	█	█	█	█	█	█	█	█	█	█
	EtherCAT, no connection established	Off											
	Connection established	50% Flash (1Hz)	█	█	█	█	█	█	█	█	█	█	█
	Communication active	Flickering	█	█	█	█	█	█	█	█	█	█	█

Dimensions

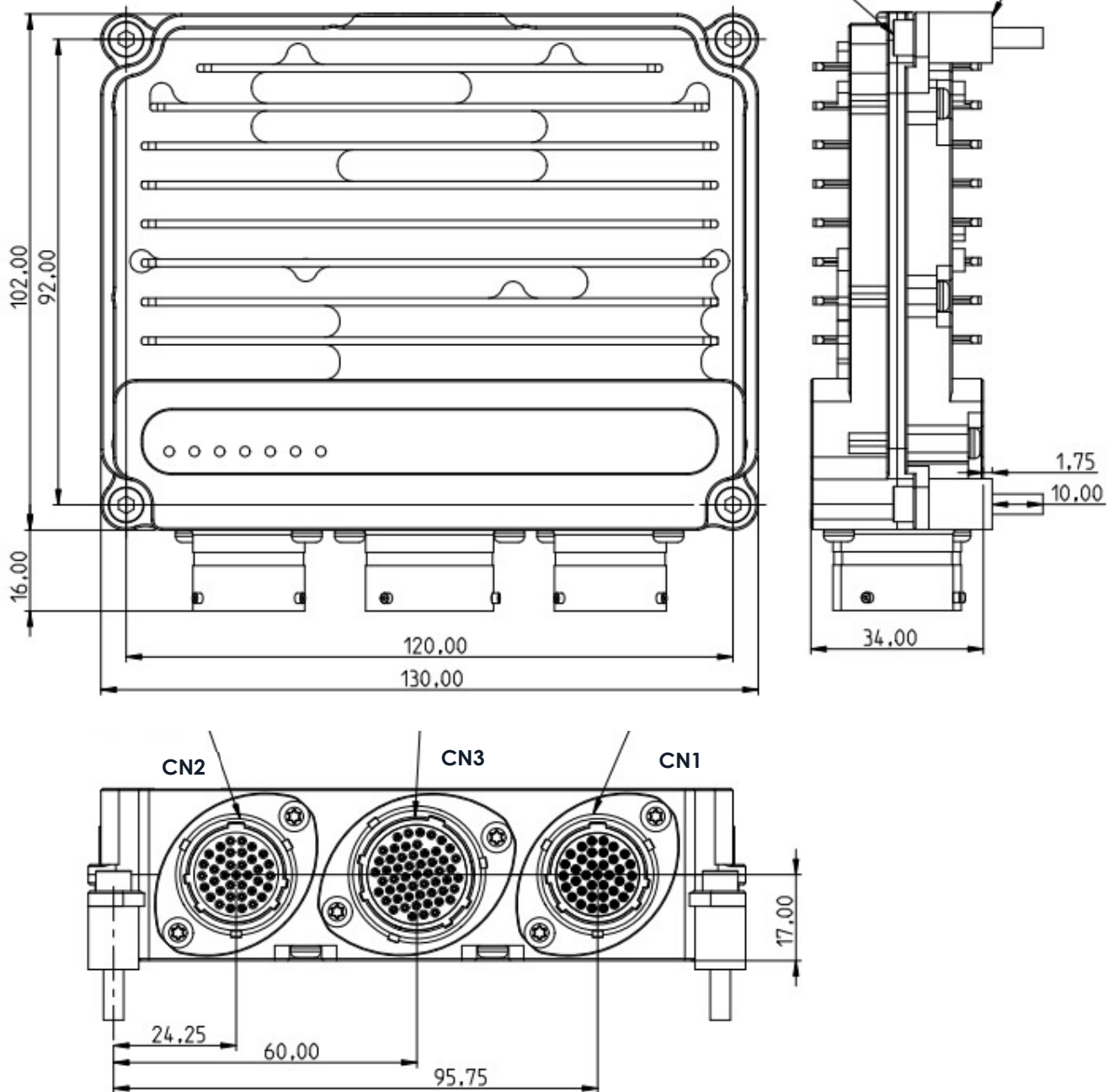

Installation

- Make sure that the unit is protected against severe vibrations by mounting using supplied AV mounting kit. Also make sure that the unit is not fouling other structures which may experience severe vibrations.
- Make sure that the unit is mounted in a position where the unit will not come into contact with liquid.
- Make sure that the unit is positioned in an area with sufficient cooling air flow to prevent overheating.
- Make sure that the unit is mounted away from sources of electrical interference.

Connector information

Please note, pin allocation is in functional order, not pin number order.

CN1

Connector	Mating connector
AS214-35PN	AS614-35SN

Connector information

Pin	520	540	560	Description
6	BATT+	BATT+	BATT+	Battery supply +VE
22	BATT+	BATT+	BATT+	
7	BATT-	BATT-	BATT-	Battery supply -VE
5	ETH1000+1	ETH1000+1	ETH1000+1	Ethernet 1000BaseT +ve for PC comms
4	ETH1000-1	ETH1000-1	ETH1000-1	Ethernet 1000BaseT -ve for PC comms
3	ETH1000+2	ETH1000+2	ETH1000+2	Ethernet 1000BaseT +ve for PC comms
21	ETH1000-2	ETH1000-2	ETH1000-2	Ethernet 1000BaseT -ve for PC comms
20	ETH1000+3	ETH1000+3	ETH1000+3	Ethernet 1000BaseT +ve for PC comms
2	ETH1000-3	ETH1000-3	ETH1000-3	Ethernet 1000BaseT -ve for PC comms
1	ETH1000+4	ETH1000+4	ETH1000+4	Ethernet 1000BaseT +ve for PC comms
19	ETH1000-4	ETH1000-4	ETH1000-4	Ethernet 1000BaseT -ve for PC comms
15	ETH1-RX+1	ETH1-RX+1	ETH1-RX+1	Ethernet 100BaseT for car comms RX+
14	ETH1-RX-1	ETH1-RX-1	ETH1-RX-1	Ethernet 100BaseT for car comms RX-
28	ETH1-TX+1	ETH1-TX+1	ETH1-TX+1	Ethernet 100BaseT for car comms TX+
16	ETH1-TX-1	ETH1-TX-1	ETH1-TX-1	Ethernet 100BaseT for car comms TX-
12	ETH2-RX+2	ETH2-RX+2	ETH2-RX+2	Ethernet 100BaseT for car comms RX+
26	ETH2-RX-2	ETH2-RX-2	ETH2-RX-2	Ethernet 100BaseT for car comms RX-
27	ETH2-TX+2	ETH2-TX+2	ETH2-TX+2	Ethernet 100BaseT for car comms TX+
13	ETH2-TX-2	ETH2-TX-2	ETH2-TX-2	Ethernet 100BaseT for car comms TX-
30	CANH1	CANH1	CANH1	CAN port 1
18	CANL1	CANL1	CANL1	
29	CANH2	CANH2	CANH2	CAN port 2
17	CANL2	CANL2	CANL2	
34	CANH3	CANH3	CANH3	CAN port 3
35	CANL3	CANL3	CANL3	
24	CANH4	CANH4	CANH4	CAN port 4
33	CANL4	CANL4	CANL4	
11	CANH5	CANH5	CANH5	CAN port 5
25	CANL5	CANL5	CANL5	
10	LIN1	LIN1	LIN1	LIN bus master 1
9	LIN2	LIN2	LIN2	LIN bus master 2
36	RS232-TX1	RS232-TX1	RS232-TX1	RS232 serial comms transmit data (Badenia to external)
32	RS232-TX2	RS232-TX2	RS232-TX2	RS232 serial comms transmit data (Badenia to external)
37	RS232-RX1	RS232-RX1	RS232-RX1	RS232 serial comms receive data (external to Badenia)
31	RS232-RX2	RS232-RX2	RS232-RX2	RS232 serial comms receive data (external to Badenia)
8	DEBTX	DEBTX	DEBTX	Debug comms transmit data
23	DEBRX	DEBRX	DEBRX	Debug comms receive data

Connector information

Please note, pin allocation is in functional order, not pin number order.

CN2

Connector	Mating connector
AS214-35SN	AS614-35PN

Pin	520	540	560	Description
26	AIN1	AIN1	AIN1	8 x Analogue inputs Software selectable 1K8 pull-up resistor Input filter 234kHz ADC filter response 22.5kHz 0 to 5v input with 16-bit resolution
12	AIN2	AIN2	AIN2	
25	AIN3	AIN3	AIN3	
11	AIN4	AIN4	AIN4	
9	AIN5	AIN5	AIN5	
10	AIN6	AIN6	AIN6	
8	AIN7	AIN7	AIN7	
24	AIN8	AIN8	AIN8	
7	AIN9	AIN9	AIN9	12 x Analogue inputs Input filter 234kHz ADC filter 22.5kHz 0 to 5v input with 16-bit resolution
23	AIN10	AIN10	AIN10	
22	AIN11	AIN11	AIN11	
6	AIN12	AIN12	AIN12	
21	AIN13	AIN13	AIN13	
5	AIN14	AIN14	AIN14	
20	AIN15	AIN15	AIN15	
4	AIN16	AIN16	AIN16	
2	AIN17	AIN17	AIN17	
3	AIN18	AIN18	AIN18	
1	AIN19	AIN19	AIN19	4 x Digital inputs DF11i, Selectable 3k3 pull-up to 5v or level shift for passive sensors
19	AIN20	AIN20	AIN20	
17	DIGIN1	DIGIN1	DIGIN1	
18	DIGIN2	DIGIN2	DIGIN2	
36	DIGIN3	DIGIN3	DIGIN3	
30	DIGIN4	DIGIN4	DIGIN4	Digital input level. IR lap timing and switches. 3k3 pull-up
35	DIGIN5	DIGIN5	DIGIN5	400Hz PWM maximum switching rate Switches between ground and battery voltage @700mA
16	HSD1	HSD1	HSD1	3 x 5v excitation @100mA
29	HSD2	HSD2	HSD2	
13	EXT5PSU1	EXT5PSU1	EXT5PSU1	
14	EXT5PSU2	EXT5PSU2	EXT5PSU2	2 x 5v or 12v software selectable excitation 5v @ 100mA, 12v @ 700mA
27	EXT5PSU3	EXT5PSU3	EXT5PSU3	
15	EXT5/12PSU1	EXT5/12PSU1	EXT5/12PSU1	5 x Grounds These are all common connections which can be used for any ground connection
28	EXT5/12PSU2	EXT5/12PSU2	EXT5/12PSU2	
31	Sensor GND	Sensor GND	Sensor GND	
32	Sensor GND	Sensor GND	Sensor GND	
33	Sensor GND	Sensor GND	Sensor GND	
34	Sensor GND	Sensor GND	Sensor GND	
37	Sensor GND	Sensor GND	Sensor GND	

Connector information

Please note, pin allocation is in functional order, not pin number order.

CN3

Connector	Mating connector
AS216-35SN	AS616-35PN

Pin	520	540	560	Description
14	N/A	AIN21	AIN21	20x Analogue inputs Input filter 234kHz ADC filter 22.5kHz 0 to 5v input with 16-bit resolution
21	N/A	AIN22	AIN22	
1	N/A	AIN23	AIN23	
5	N/A	AIN24	AIN24	
11	N/A	AIN25	AIN25	
4	N/A	AIN26	AIN26	
10	N/A	AIN27	AIN27	
17	N/A	AIN28	AIN28	
13	N/A	AIN29	AIN29	
6	N/A	AIN30	AIN30	
20	N/A	N/A	AIN31	
12	N/A	N/A	AIN32	
19	N/A	N/A	AIN33	
18	N/A	N/A	AIN34	
27	N/A	N/A	AIN35	
34	N/A	N/A	AIN36	
26	N/A	N/A	AIN37	
33	N/A	N/A	AIN38	
25	N/A	N/A	AIN39	
32	N/A	N/A	AIN40	
9	DIGIN6	DIGIN6	DIGIN6	4x Digital inputs DF11i, Selectable 3k3 pull-up to 5v or level shift for passive sensors
8	DIGIN7	DIGIN7	DIGIN7	
3	N/A	DIGIN8	DIGIN8	
7	N/A	N/A	DIGIN9	
2	N/A	N/A	DIGIN10	1x Digital input level. IR lap timing and switches. 3k3 pull-up
16	EXT5PSU4	EXT5PSU4	EXT5PSU4	3x 5v excitation @100mA
23	EXT5PSU5	EXT5PSU5	EXT5PSU5	
24	EXT5PSU6	EXT5PSU6	EXT5PSU6	
31	EXT5/12PSU3	EXT5/12PSU3	EXT5/12PSU3	2x 5v or 12v software selectable excitation 5v @ 100mA, 12v @ 700mA
39	EXT5/12PSU4	EXT5/12PSU4	EXT5/12PSU4	
28	BATT+	BATT+	BATT+	Battery supply +VE
29	BATT+	BATT+	BATT+	Battery supply +VE
35	BATT-	BATT-	BATT-	Battery supply -VE
22	GND	GND	GND	2x grounds
30	GND	GND	GND	

CN3 (continued)

Pin	520	540	560	Description
37	Sensor GND	Sensor GND	Sensor GND	2x grounds
45	Sensor GND	Sensor GND	Sensor GND	
49	CANH6	CANH6	CANH6	CAN port 6
53	CANL6	CANL6	CANL6	
50	N/A	N/A	CANH7	CAN port 7
54	N/A	N/A	CANL7	
36	N/A	N/A	CANH8	CAN port 8
43	N/A	N/A	CANL8	
38	HSD3	HSD3	HSD3	400Hz PWM maximum switching rate Switches between ground and battery voltage @700mA
46	HSD4	HSD4	HSD4	
41	ECATTX+	ECATTX+	ECATTX+	EtherCAT 100BaseT for system expansion
47	ECATTX-	ECATTX-	ECATTX-	
48	ECATRX+	ECATRX+	ECATRX+	
42	ECATRX-	ECATRX-	ECATRX-	
40	N/A	N/A	N/A	
44	N/A	N/A	N/A	
51	N/A	N/A	N/A	
52	N/A	N/A	N/A	
55	N/A	N/A	N/A	



Recycling and Environmental Protection

Cosworth Electronics is committed to conducting its business in an environmentally responsible manner and strive for high environmental standards.

Manufacture: Cosworth products comply with the appropriate requirements of the Restriction of Hazardous Substance (RoHS).

Disposal: Electronic equipment should be disposed of on accordance with the regulations in force and in particular in accordance with the Waste in Electrical and Electronic Equipment directive. (WEEE).

Battery

This equipment contains a rechargeable battery (Manganese Silicon Lithium).

The equipment may be returned to Cosworth Electronics for a replacement battery. A charge will be made for this service.

To remove the battery for recycling:

- Remove the case(s).
- Remove printed circuit boards from the case.
- Remove the battery from the printed circuit board.
- Dispose of the battery in accordance with the regulations in force.

Removal of the battery will result in the warranty of the unit being void.



Document: 29L-650080-P

Rev: 4

All Information in this document is correct as of 23/08/2024

T (UK) +44 (0) 1604 598 300

T (US) +1 (317) 644 1037

E enquiries@cosworth.com

W www.cosworth.com

© Copyright Cosworth Electronics Ltd | All Content is Proprietary and Confidential. Brookfield Technology Centre, Twentypence Road, Cottenham, Cambridge, CB24 8PS.

COSWORTH

Enabling Greatness for over  years